

3DEXPERIENCE®

10 REASONS 3DEXPERIENCE CATIA GIVES MECHANICAL ENGINEERS AN ADVANTAGE



Engineering is critical to Business Success

With significant global competition, it is hard for companies to bring new products to market that will stand out. The world has gotten smaller, and with technology advancements, many small companies now have access to resources that used to be only available to the largest companies, but they need to make sure they are using the right technology to get that competitive edge. Meanwhile, large companies need to stay ahead to protect their market share.

The key to bringing competitive products to market lies in engineering. A McKinsey study found that companies that excel at design grow revenues and shareholder returns at nearly twice the rate of their industry peers.¹ However, to achieve design success, engineers must be empowered with the best tools available.

What it takes for Mechanical Engineers to Succeed

Why is engineering so critical? In a study by Tech-Clarity, they asked companies why customers buy their products (*Fig. 1*).²



Fig. 1: Why customers buy your products?

Data sources: Tech-Clarity

You can see that when the most successful companies, which they called Top Performers, are compared to Others, Top Performers are more likely to cite multiple reasons why customers buy their products. This means engineers need to simultaneously focus on numerous criteria to be successful while still having the time and flexibility to innovate.

Innovation is particularly critical to success as it is the biggest differentiator between Top Performers and Others. To innovate, engineers must be able to iterate their design as much as possible early on to explore many ideas and arrive at the best design.

This is because designs have the most flexibility during the early lifecycle stages, and it doesn't cost much to make changes. However, as you get closer to release to manufacturing, more of the design is complete, so changes have a more significant impact, making them more costly (*Fig. 2*). Once the design is released, steel and raw materials are ordered, tooling is produced, component suppliers are engaged, and production begins. At this point, any change becomes extremely costly. To avoid this, engineers need the right tool that has the flexibility to innovate, high-quality products that will attract customers, yet powerful enough to offer the insights needed to make the right engineering decisions and catch problems as early as possible.

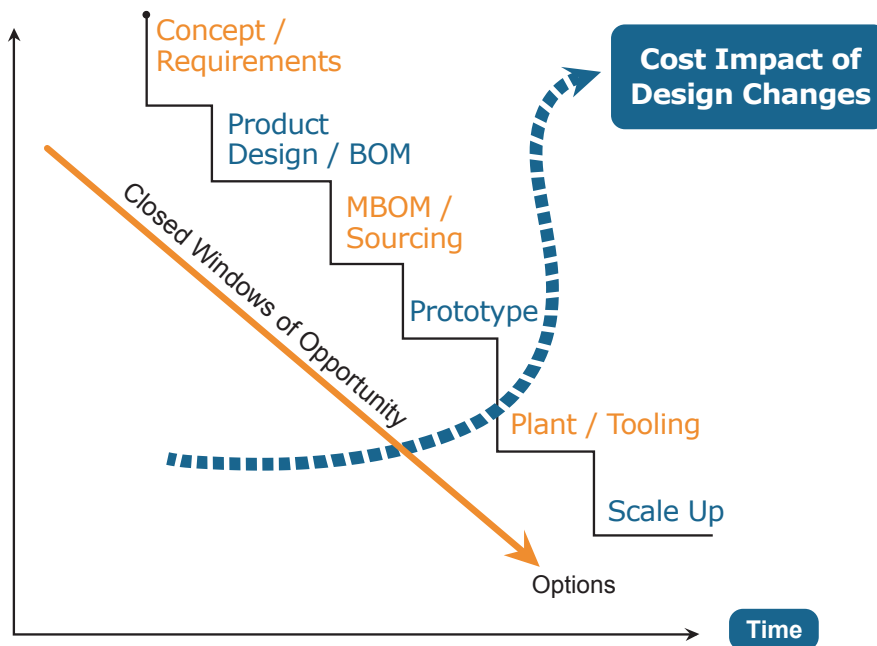

Fig.2: Closing Windows of Opportunity

Data sources: Tech-Clarity

Why CATIA?

3DEXPERIENCE CATIA offers all the tools mechanical engineers need to be the best engineers they can, while empowering them with the latest technology. It is the only solution that can achieve any design, regardless of industry, and will never hold engineers back. Plus, it has the flexibility and capabilities that will scale to your needs as your business grows.

With **3DEXPERIENCE CATIA**, you will be able to:

- Model Anything
- Learn It Easily
- Reuse Geometry
- Work on Large Assemblies with Ease
- Optimize and Test with Simulation
- Assess Motion
- Design for Manufacturability
- Adopt Model Based Definition (MBD)
- Manage Product Data and Adapt to Differing Needs
- Collaborate by Connecting People, Processes, and Data

Let's explore how this combination of powerful capabilities will empower mechanical engineers to develop more competitive, more profitable products.

1. Model Anything

Modeling capabilities are the most critical aspect of a CAD tool. Engineers can not be held back and should not struggle to get their CAD tool to model what they want. Plus, the digital model must accurately reflect reality. Compromising on this means late changes and more physical prototypes, which add even more time and cost. Instead, with a very accurate modeler, engineers can spend more time on innovation.

CATIA is the Best Geometrical Core Modeler

CATIA is known for its high geometric accuracy. It is so robust and stable, engineers can easily modify their designs to quickly iterate without worrying about the model failing or wasting hours trying to fix it.

Its modeling capabilities range from highly engineered aircraft to aesthetically pleasing wine glasses. Regardless of your product's complexity, knowing it is trusted by the aerospace and defense industry, where lives depend on its accuracy, you can be confident its accuracy will save you money in physical prototypes.

Unbeatable Surfacing

Superior surfacing capabilities will give you a competitive advantage. For example, aerodynamic surfaces improve energy efficiency. Additionally, aesthetically pleasing designs will catch a customer's attention due to the "cool-factor." These qualities are invaluable in the aerospace & defense, automotive, high-tech, consumer, and industrial equipment industries.

A surface has no thickness in CAD, so it is more flexible and easier to manipulate than solid geometry; therefore, it is easier to create beautiful organic shapes and Class A surfaces with surface modeling. A Class A surface is smooth and continuous, possessing the ideal reflective qualities critical for aerodynamics and aesthetics. However, the tangency and continuity calculations are so complex; you need a CAD tool with the surfacing capabilities designed for precisely this. Only **CATIA** combines highly accurate 3D solid modeling with Class A surfacing capabilities.



2. Learn It Easily

Engineering time is too valuable to waste on non-value-added work. CAD tools should support the design process, not control it or create unnecessary barriers that slow engineers down. Tedious menu picks, hunting around for functionality, even learning a new user interface for specialized applications can waste engineering time.

Intuitive User Experience

The user interface for **3DEXPERIENCE CATIA** has been updated with these concerns in mind. We leveraged our expertise about how engineers design, including our **SOLIDWORKS** users, and applied modern approaches to ease of use. This makes **3DEXPERIENCE CATIA** very easy to learn and use for both new and experienced users.

Contextual menus offer logical options based on your selected surface, plane, curve, edge, or feature. For example, if you select an edge, you will only see relevant commands like "Fillet" and "Chamfer." Also, the streamlined user interface and popup menus mean less mouse travel so that engineers work more efficiently. Engineers can also add frequently used commands to an action pad for easy access. Finally, every application within **3DEXPERIENCE CATIA** reflects the same logic and workflows, so the consistent user interface makes it easy to learn how to use specialized functions that will save time.

Direct Modeling

3DEXPERIENCE CATIA also offers the flexibility of direct modeling, if desired. Direct modeling allows users to modify surfaces with a simple "push and pull," making it easy to do quick modifications. It also makes the software more accessible to casual users who want to do a quick mock-up. In addition, this functionality is especially convenient when making changes to Multi-CAD or STEP files. Consequently, engineers don't have to worry about the type of CAD data they get because it will be easy to work with it no matter what.

Productivity Boosters

3DEXPERIENCE CATIA has several ease-of-use features that will boost engineering productivity. For example, Auto Draft will automatically draft all desired faces in a model, while Auto Fillet will put a fillet on all edges. For further productivity improvements, **3DEXPERIENCE CATIA** Knowledgeware allows you to capture company knowledge and apply rules or formulas to models. For even more automation, **3DEXPERIENCE CATIA** also supports scripting.

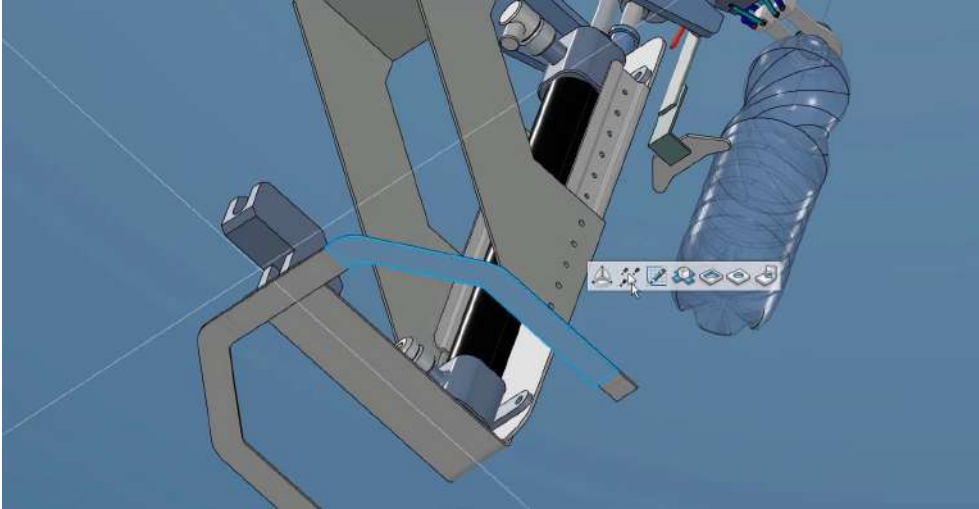

3. Reuse Geometry

During design, nothing is more frustrating than recreating previously completed work. Not only does it waste time, but there is also a risk of potentially introducing errors if there are any deviations from the original. How much better would it be if engineers could just reuse that existing work, regardless of format? The powerful surface modeling capabilities discussed in the Model Anything Section also make it easier to deal with this.

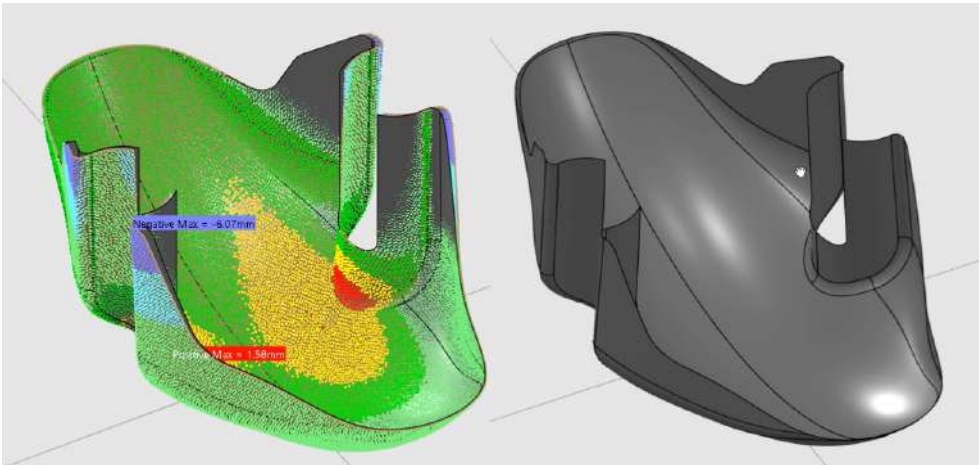

Multi-CAD

Most engineers have to deal with multi-CAD data, whether it comes from suppliers, customers, others in your company, or legacy data. The good news is that **3DEXPERIENCE CATIA** makes it easy to work with it and modify it. **3DEXPERIENCE CATIA** also has powerful surface healing capabilities to repair imported geometry.

Converting the Physical to Digital

3DEXPERIENCE CATIA also supports reverse engineering with capabilities that allow engineers to quickly construct a 3D surface from a point cloud. It can also support the concept phase by importing a point cloud from a clay model or concept prototype. This functionality even helps validate a manufactured part, including a 3D printed one, by comparing the converted scanned point cloud of the physical part to the as-designed digital model. Engineers can then analyze differences.

3DEXPERIENCE CATIA is so powerful; it can even handle a job as big as creating a digital

version of your factory. For example, suppose you would like to simulate factory operations to optimize productivity, ensure safety, and catch potential problems. In that case, you can scan your factory and import the data to create a digital model.

4. Work on Large Assemblies with Ease

Because the multiple engineers working on the individual components in an assembly may be spread across various locations, time zones, and perhaps even involve third-party suppliers and partners, collaboration can be a challenge. To ensure the components fit together, engineers must constantly keep each other informed of their work. Unfortunately, poor collaboration is common, and engineers spend 29% of their time working with outdated data, which has a significant negative business impact.³(Fig.3)

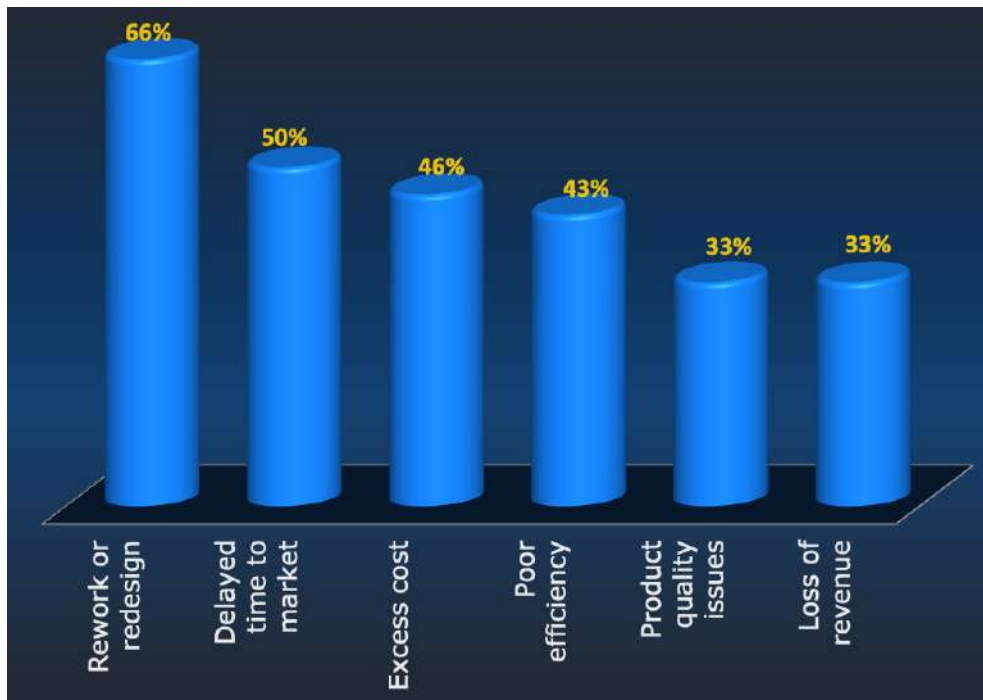

Fig.3: Business impacts of outdated information

Data sources: Tech-Clarity

If no one communicates a simple change to a mounting screw location or a minor tweak to a surface contour, there will be problems during assembly.

With traditional tools, engineers can try to overcome this by retrieving the entire assembly, but the data will quickly become outdated. Plus, the computational power required to work with all those components in memory can be painful. In some cases, the assembly may be so large; it may not even be possible to retrieve it.

Superior Performance

3DEXPERIENCE CATIA was architected to take advantage of modern technologies to solve these problems. Because of its unique data architecture, **3DEXPERIENCE CATIA** can retrieve the largest assemblies faster than other CAD tools. Even if the assembly contains over a million components, **3DEXPERIENCE CATIA** will have no issues retrieving it, something most CAD tools cannot do. You can then easily explore large assembly structures to get a complete view of the entire product. While helpful for engineers to understand the context of their work, this is especially valuable for product management and architects as they make critical decisions about the direction of the product.

Isolate Exactly What You Need

Engineers can then filter their view to focus on the specific area he or she is working on. This way, the view is not cluttered with extraneous information, but still allows engineers to work in the context of the relevant parts of the assembly that may impact their work.

3DEXPERIENCE CATIA offers multiple filtering capabilities to make it as convenient as possible. For example, you can draw a box around only the portion you would like to see, and everything else will be removed.

Enable Concurrent Engineering

The combination of these capabilities enables true concurrent engineering. As engineers

design their components, they can work in the context of the rest of the assembly and have real-time visibility into others' work.

They automatically see changes that impact them and can modify their design right away, rather than finding out weeks or months later that there is a conflict. This approach also makes it easy to identify interferences and conduct a clash analysis so that when the final product is ready for assembly, you can be confident it will come together as intended.

With **3DEXPERIENCE CATIA**, engineers also have the flexibility to retrieve what they need, while the rest of the assembly is a lightweight version or a ghost display. This way, they see the other components, but only the part they are working on is in memory. As a result, performance is much faster.

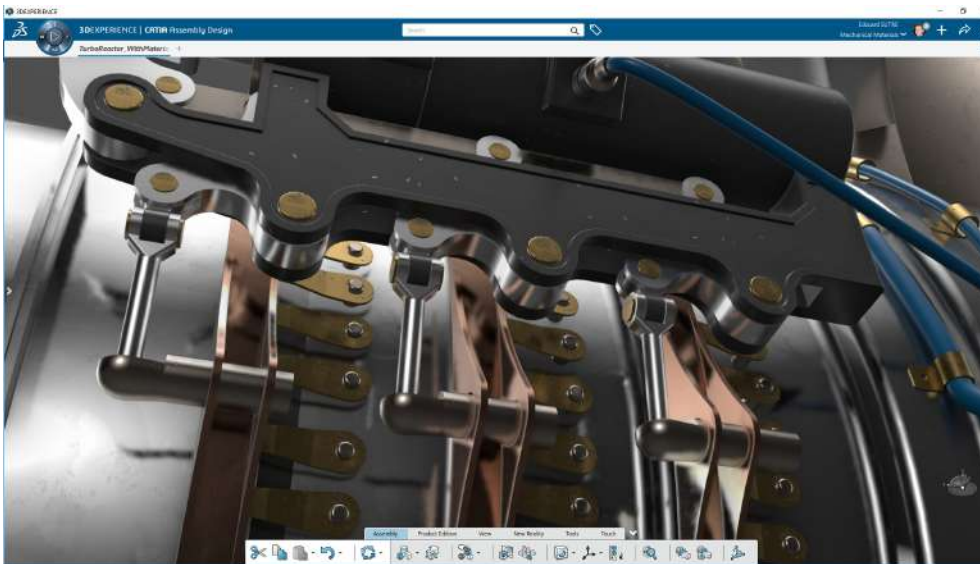

5. Optimize and Test with Simulation

One of the most critical ways to avoid late-stage, expensive problems is to catch those problems as earlier as possible. At the same time, engineers must optimize multiple criteria to meet customer requirements. Given everything they must consider, this isn't easy, and in fact, a Tech-Clarity study finds that 44% of engineers find that these decisions are getting even harder.⁴ This is due to the increased requirements for higher quality and performance, the amount of information they must gather to support decisions, time constraints, and the number of components and configurations they must consider.

It has gotten nearly impossible to make these decisions without any guidance, especially as the most experienced engineers approach retirement age. Incidentally, Tech-Clarity found that when comparing problem-solving methods, including seeking expert advice and waiting for physical testing results, engineers were 3.7 times more likely to say that simulation was the ideal way to solve design problems.⁵ Simulation helps engineers find design problems sooner, and the earlier it is used, the more engineers can optimize their designs by using it as a guide for design decisions.

One Platform

While simulation is an incredibly powerful tool, it can take time to prepare a model for analysis. This is yet another reason why **3DEXPERIENCE CATIA** is such a compelling solution. Design and simulation share the same model, so no one wastes time exporting and importing models or investing hours preparing for analysis. Moreover, engineers don't have to wait days to get the analyst's results, only to realize they are outdated due to subsequent design changes. With **3DEXPERIENCE CATIA**, the analysis will always reflect the latest design changes.

Access to Expertise

While **3DEXPERIENCE CATIA** makes it easy for design engineers to conduct a stress analysis and evaluate structural integrity early on, design engineers do not always have the expertise to do the analysis on their own. Instead, they may need guidance from an

analyst. In fact, in a Tech-Clarity survey, 83% of Top Performing companies said that if design engineers and analysts could collaborate more easily, they would get even more value from simulation.⁶ Also, companies overwhelmingly said that the best way for design engineers and simulation experts to collaborate would be to send a link to collaborate on the model in real-time.

With **3DEXPERIENCE CATIA**, engineers have exactly these capabilities. Design engineers can invite analysts to view the model with them, and analysts can provide analysis feedback. This way design engineers will be confident in their work with needed guidance to support better design decisions.

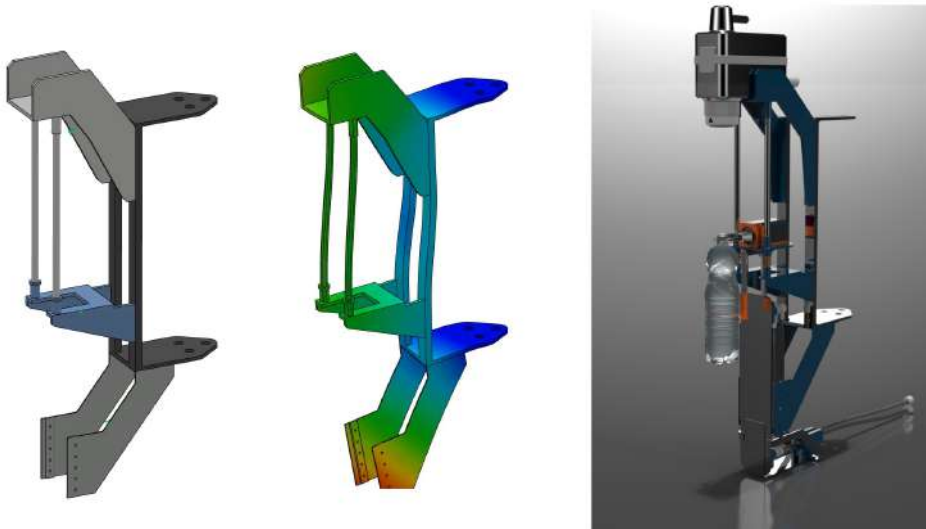

6. Assess Motion

Not all designs are static, so in addition to ensuring the product will be strong enough, engineers also often have to assess motion. Again, if they can do this early during the design process, they can save significant time and cost by optimizing the design when there is the most flexibility.

While a powerful capability, traditionally, it can take time to set up the analysis. Defining each assembly constraint and the types of joints can be tedious and especially frustrating when it is already in the design model.



Streamlined Kinematics and Dynamics Simulations

3DEXPERIENCE CATIA drastically reduces the steps to prepare a kinematics analysis as it already understands the existing assembly constraints and degrees of freedom associated with each connection. The weight, center of gravity, and material are also automatically available to engineers for a kinematics simulation. It can then accurately calculate speed and accelerations to conduct a realistic analysis.

Engineers can also evaluate the impact of springs, stiffness, damping, motor torque, and more, arming them with the insights required to make the best design decisions. Because it is all one model, you can start looking at kinematics and dynamics as early as the concept stage with only a 2D mechanism. You can then continually assess it as the design evolves into a higher fidelity model.

The analysis also allows engineers identify clashes and even verify that components can work together. In addition to a single mechanism, **3DEXPERIENCE CATIA** is powerful enough to assess multiple subassembly mechanisms simultaneously. This will result in a higher quality design and lower costs due to fewer physical prototypes.

7. Design for Manufacturability

Just because engineers can design something doesn't necessarily mean it can be manufactured. As discussed earlier, design errors found late in the cycle cost companies the most, especially if the design was released.

Unfortunately, with the most experienced engineers approaching retirement, companies are losing valuable manufacturing knowledge within engineering departments. Worse, companies are also losing manufacturing knowledge in production environments.

A Deloitte and The Manufacturing Institute study revealed that 89 percent of executives agree there is a talent shortage in the US manufacturing sector,⁷ and the pandemic only made it worse.⁸ Consequently, it is critical that companies arm engineers with better tools to help them assess manufacturability during design.

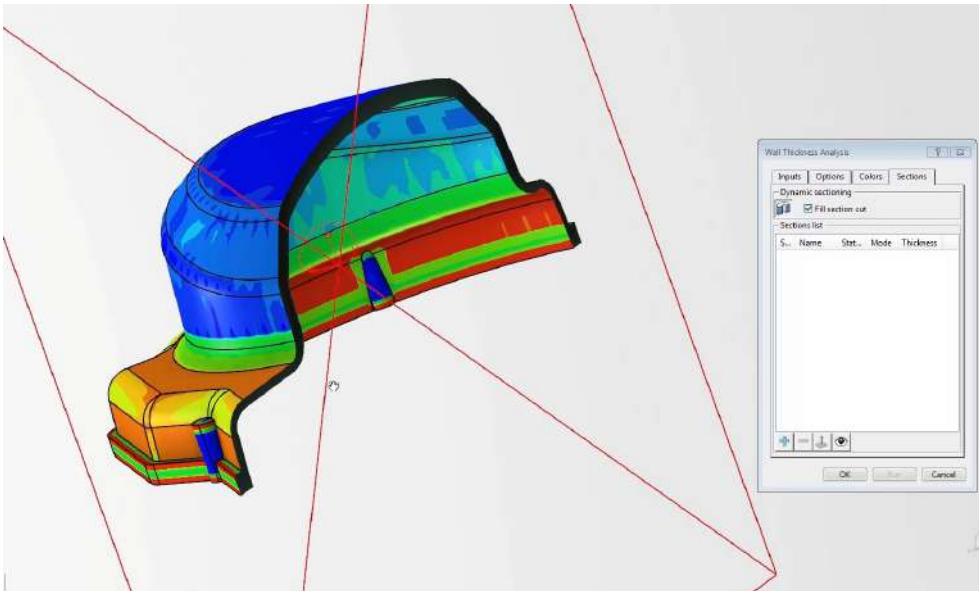

Flexibility and Guidance Regardless of Production Method

Typically, products contain a mix of materials and rely on various manufacturing methods to produce each component. **3DEXPERIENCE CATIA** has the flexibility to use the materials and manufacturing methods you need, whether it is plastic, steel, composites, or other material. It supports various manufacturing processes, including injection molding, casting and forging, stamping, traditional machining, sheet metal bending, welding, and 3D printing. Not only do the specialized apps provide design guidance to help you design for manufacturing, but if you are not sure which production method would be best, it can help you there too. You can quickly assess different approaches, and it will give you a cost estimate so that engineers can make the best decision that will yield greater profitability.

Engineers will also benefit because there is a consistent user interface, regardless of the production method, making it easier to adopt new applications as the design calls for it. In addition, the associative model and the platform ensures that changes to the part will automatically update associated tooling and manufacturing processes data. The platform also provides manufacturing with early visibility so that they can start planning sooner.

3DEXPERIENCE CATIA provides numerous insights to improve part quality and increase profitability. For example, the analysis of a plastic part may show that there will be a

weld line in an area that could create a weakness. Armed with this information, engineers can adjust the part design or change the gate location to move or avoid the weld line. For an additive part, it can help reduce supports to save money while cutting postprocessing time. **3DEXPERIENCE CATIA** can also provide guidance to minimize stroke height for a stamped part to accelerate cycle time.

Manufacturability and Compliance Checks

3DEXPERIENCE CATIA can check a part for manufacturability and flag problem areas based on the selected manufacturing method. For example, engineers can ensure sheet metal parts can be bent, even if the part has a complex curvature. It can also check for compliance with industry, corporate, or customer-specific plant standards. This compliance check ensures you do not provide customers with out-of-spec parts that could hurt your business reputation.

8. Adopt Model-Based Definition (MBD)

After completing the design, it's ready to be released to manufacturing. In a study, TechClarity found that engineers spend 31% of their design time on drawings.⁹ Considering this involves documenting completed work, it basically duplicates efforts. What if engineers could spend more of that time on innovation and engineering? Trends to adopt model-based definition (MBD) move companies in this direction by making the 3D model the master.

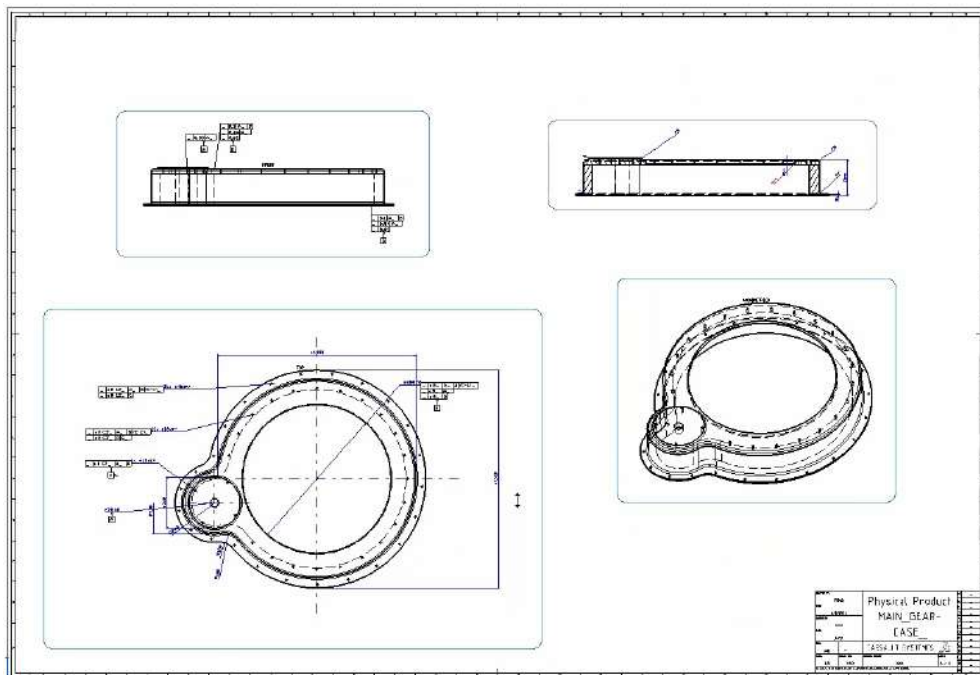
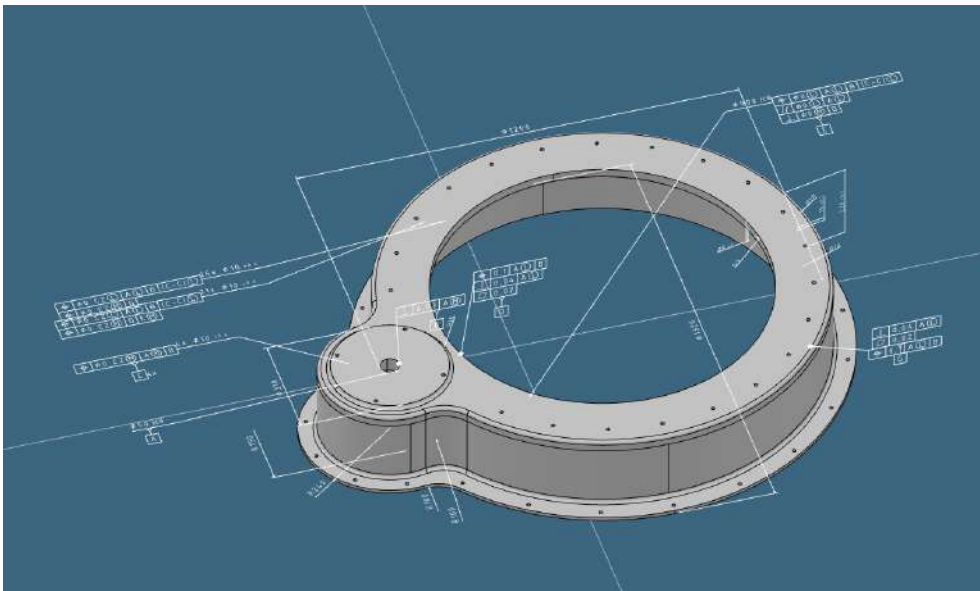

Why 3D?

A separate 2D drawing creates risks of inconsistencies between the 3D model and the 2D drawing. For example, after printing a 2D drawing, it is separated from the 3D model and will not reflect changes due to a manufacturability issue, design error, customer request, or other reason. Then the shop floor will rely on outdated information that can result in time and money-wasting reworked and scrap.

Interpreting 2D is also a specialized skill that newer staff may not have, especially after losing skilled manufacturing workers. This can easily lead to errors due to a misunderstanding. New workers will likely find 3D more intuitive, which will reduce the risk of errors.

3DEXPERIENCE CATIA's support for MBD can also help a company transition to using 3D as the master to eventually evolve to a Model-Based Enterprise (MBE).

Generative Tolerancing

Manufacturing needs tolerances on all dimensions. However, not only is adding them tedious and time-consuming, but with the loss of manufacturing knowledge, many engineers do not realize the impact of improper tolerancing. Consequently, tolerances are often tighter than necessary, so they unknowingly add significant production costs.

3DEXPERIENCE CATIA solves this with generative tolerancing. This automates tolerancing saving significant time, while also automatically applying rules and standards to optimize tolerances. These standards can be international or corporate-specific. By using more appropriate tolerances, manufactures can save significant costs.

9. Manage Product Data and Adapt to Differing Needs

Product Data Management (PDM) is a valuable tool to manage engineering data and support version control. Product Lifecycle Management (PLM) extends that to manage the engineering data and processes across the lifecycle. Most engineers want to focus their time on great engineering, not managing data.

Seamless Environment

With **3DEXPERIENCE CATIA**, engineers don't have to leave the design environment as PLM is fully integrated into the user experience. With a more traditional PDM or PLM system, it can take so long just to check data in and out, many engineers delay checking-ins, which means other engineers may end up working with outdated information. Then they may have to waste hours manually comparing versions to understand the changes and redoing their work.

3DEXPERIENCE CATIA uses an approach that is similar to Google Docs™. With Google Docs, anyone invited to view a document can see the latest version in real-time. Similarly, anyone invited to a project in **3DEXPERIENCE CATIA** sees model updates in real-time. Plus, it is not file-based, but rather a database platform, so you don't have to waste time waiting to check files in and out.

The solution also offers capabilities to manage component families so that you can configure designs for specific needs. **3DEXPERIENCE CATIA** also provides a "where used" function so that if a component changes, you can easily identify which assemblies or subassemblies have used it and need to be updated.

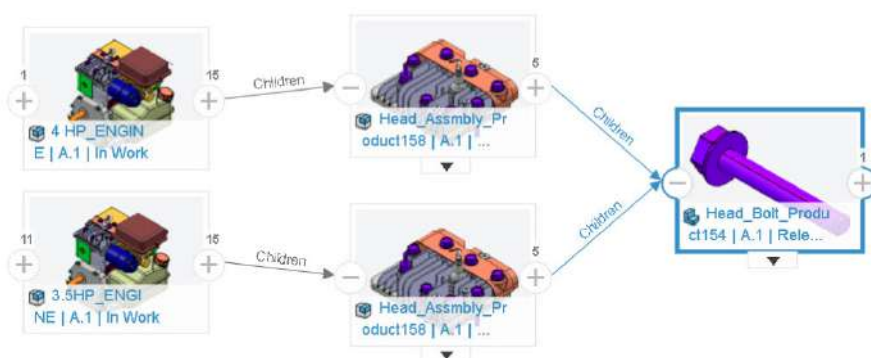

10. Collaborate by Connecting People, Processes, and Data

While **3DEXPERIENCE CATIA** offers all the capabilities a mechanical engineer needs, it brings even more value by bringing everything together on a collaboration platform. Product development relies heavily on collaboration, yet good collaboration is tough. A Tech-Clarity report found that an overwhelming 93% of companies report they need to improve collaboration with different groups.¹⁰

The study found that within engineering, poor collaboration results in more design rework, missed deadlines, longer design cycles, more time wasted on non-value-added tasks, and design errors. These impacts snowball and hurt the business, so profitability takes a hit (*Fig.4*).

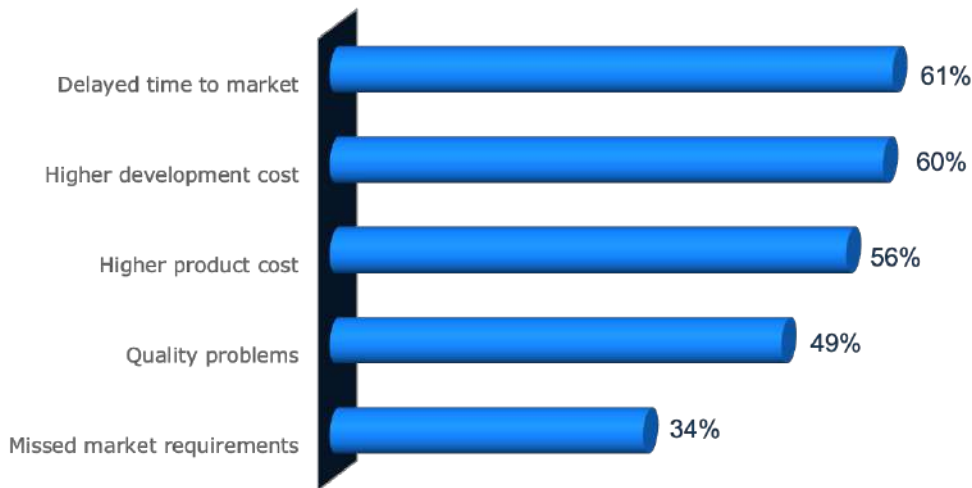

Fig.4: Impact of poor collaboration on the business

Data sources: Tech-Clarity

Better Collaboration

3DEXPERIENCE CATIA allows engineers to work together in parallel, with visibility into what each other is doing. This significantly accelerates the design process while avoiding errors due to miscommunications. Engineers across disciplines, including mechanical, electrical, and electronics, can work together in a single environment on a unified data model across the entire lifecycle during concept design, detailed design, simulation, and manufacturing.

Beyond that, even stakeholders outside of engineering can access what they need simply from a web browser. Again, this saves engineering time because they don't have to worry about interruptions from marketing, document, service, and other groups to provide them with engineering details. After all, these different groups have access to what they need when they need it, and they never have to worry about it being out of date.

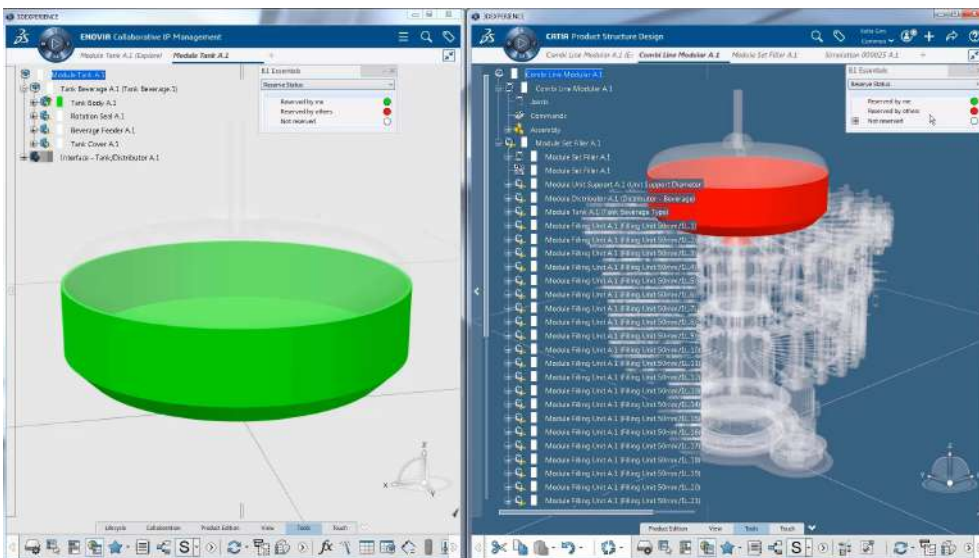

Security

Working with third parties is often a challenge. It is hard to get them the data they need, and typically it is emailed because that's the easiest and fastest way to send it. However, this creates security risks, and once you take it out of PDM or PLM, it can become outdated, making version control incredibly challenging. You also have no control or visibility into whom the recipient sends the data.

With **3DEXPERIENCE CATIA**, you can send a supplier, partner, or customer a link to the data on the platform and control the type of access they have. Then, after completing the project and you no longer want them to have access, you simply turn off their access, keeping your intellectual property (IP) secure.

Conclusion

By investing in the right design tool, your company will realize productivity gains that will boost profitability. With **3DEXPERIENCE CATIA**'s superior modeling and assembly management capabilities, engineers can expect to see a 20% to 50% gain in productivity. Then, if you complement it with the unified modeling and simulation environment and powerful design for manufacturability capabilities, and tie it all together with integrated data management on a collaboration platform, you can expect an additional 30% productivity improvement, depending on your usage and industry. Together, **3DEXPERIENCE CATIA** offers the ultimate toolset for mechanical engineers.

Flexible Implementation

3DEXPERIENCE CATIA offers three flexible implementation options:

- Dassault Systèmes Public Cloud
- Private Cloud
- On-premise

A typical PLM system can take months to implement, with significant investments in the server and software, not to mention the ongoing IT costs for maintenance. With the public cloud option, companies don't have to worry about installations, server investments, or IT costs. Instead, it is part of the service, and companies can have it running in less than an hour and start to benefit right away.

Notes

- Paper to be published under the 3DS CATIA logo
- References:
 1. Benedict Sheppard, Hugo Sarrazin, Garen Kouyoumjian, and Fabricio Dore, "The Business Value of Design," *McKinsey&Company*, 2018, <https://www.mckinsey.com/business-functions/mckinsey-design/our-insights/the-business-value-of-design>.
 2. Michelle Boucher, "How to Engineer High-Performing, Quality Products without Extra Cost," *Tech-Clarity*, 2021.
 3. Michelle Boucher, "How to Reduce Non-Value-Added Work in Engineering," *Tech-Clarity*, 2021.
 4. Michelle Boucher, "How to Survive and Win New Markets By Getting Even More Value from Simulation," *Tech-Clarity*, 2020.
 5. Ibid.
 6. Ibid.
 7. Craig Giffi, et al., "The Jobs Are Here, but Where Are the People?" *Deloitte Insights*, 2018, <https://www2.deloitte.com/us/en/insights/industry/manufacturing/manufacturing-skills-gap-study.html>.
 8. Paul Wellener, "2021 Manufacturing Industry Outlook," *Deloitte*, 2021, <https://www2.deloitte.com/us/en/pages/energy-and-resources/articles/manufacturing-industry-outlook.html>.
 9. Michelle Boucher, "How-to Guide: Adopting Model Based Definition (MBD)," *Tech-Clarity*, 2021.

10. Michelle Boucher, "What's the Cost of Poor Engineering Collaboration" *Tech-Clarity*, 2020.

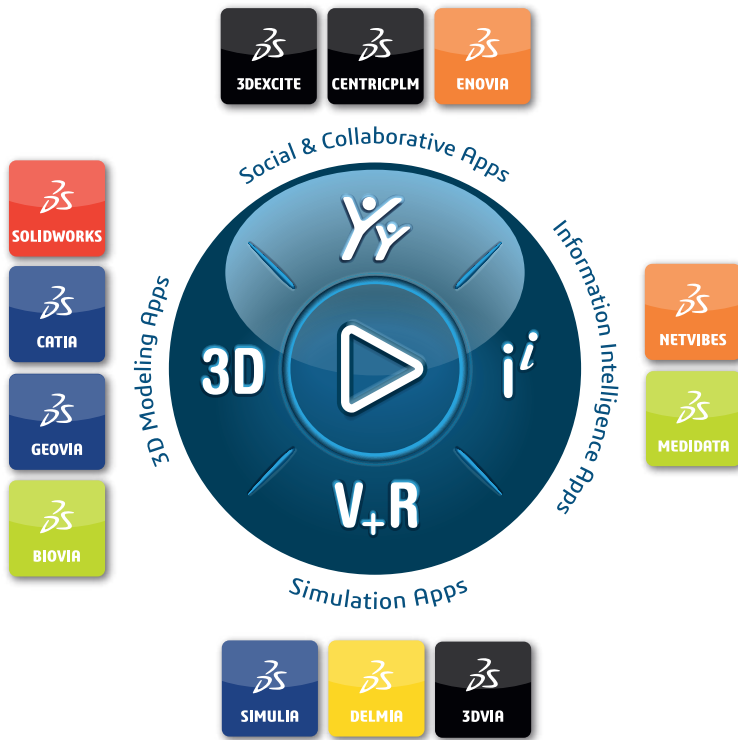

Our 3DEXPERIENCE® platform powers our brand applications, serving 11 industries, and provides a rich portfolio of industry solution experiences.

Dassault Systèmes, the 3DEXPERIENCE Company, is a catalyst for human progress. We provide business and people with collaborative virtual environments to imagine sustainable innovations. By creating 'virtual experience twins' of the real world with our 3DEXPERIENCE platform and applications, our customers push the boundaries of innovation, learning and production.

Dassault Systèmes' 20,000 employees are bringing value to more than 270,000 customers of all sizes, in all industries, in more than 140 countries. For more information, visit www.3ds.com.

Europe/Middle East/Africa
 Dassault Systèmes
 10, rue Marcel Dassault
 CS 40501
 78946 Vélizy-Villacoublay Cedex
 France

Asia-Pacific
 Dassault Systèmes K.K.
 ThinkPark Tower
 2-1-1 Osaki, Shinagawa-ku,
 Tokyo 141-6020
 Japan

Americas
 Dassault Systèmes
 175 Wyman Street
 Waltham, Massachusetts
 02451-1223
 USA

©2021 Dassault Systèmes. All rights reserved. 3DEXPERIENCE, the 3DS logo, 3D, BIOVIA, GEOVIA, SOLIDWORKS, 3DVIA, ENOVIA, NETVIBES, MEDIDATA, SIMULIA, DELMIA, and 3DEXCITE are commercial trademarks or registered trademarks of Dassault Systèmes, a French "société européenne" (Versailles Commercial Register # B 322 306 440), or its subsidiaries in the United States and/or other countries. All other trademarks are owned by their respective owners. Use of any Dassault Systèmes or its subsidiaries trademarks is subject to their express written approval.