

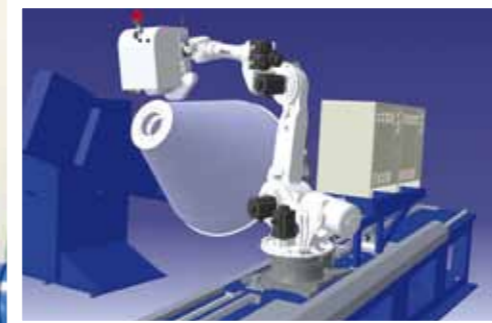

Virtual representation of robot inspection in DELMIA



Robot inspects and welds sandwich cone structure

FORCE Technology simulates inspection devices with DELMIA Cycle Time Performance

Plant maintenance often requires operators to shut down a plant during inspection and repairs. Shortening downtime reduces the costs inherent with production interruption. FORCE Technology uses simulation to pre-test its inspection devices in a virtual environment to ensure that its equipment is designed to perform right the first time.

Periodic testing for wear and potential damage is a requirement that all plants must respect. Non-destructive testing makes it possible to examine the condition or the quality of an object without damaging it. Used preventively and to improve safety, non-destructive testing helps avoid interruptions and breakdowns in production, and can often be performed without production interruptions.

It is used in many different businesses and industries, including energy, offshore, construction, chemical and petrochemical. While some checks can be done during plant operation (such as inspecting a pipe's exterior) others may require shutting down the plant, which can be extremely costly.

INSPECTION EXPERTS FOR THE HEAVY INDUSTRY

Built on a solid foundation with more than 60 years of experience, FORCE Technology focuses on product and concept development, design, production optimization and operation, and maintenance of industrial facilities.

Since downtime in any plant is expensive, FORCE Technology needs to verify beforehand that its devices work right the first time. There is no time to modify a device once in operation. "We need to go in and get the job done quickly so that the plant can start up as soon as possible," explained Christian Brandt Lauritzen, project manager, FORCE Technology. "It simply has to work right the first time."

VIRTUAL SIMULATION FOR A CUSTOM-MADE DEVICE

FORCE Technology relies on CATIA PLM Express

and DELMIA Cycle Time Performance to design and test special-design equipment before it is manufactured. "We do a feasibility study to see how big the device or manipulator can be, how we get it in and how we get it out," Lauritzen said. "We receive from the customer the geometry of the pipe or object to inspect and import this data into CATIA PLM Express. We then design the manipulator and use DELMIA to virtually simulate it in operation." Each manipulator is unique and tailored to a customer situation, which is why physical prototypes are not created. "It's a one-of-a-kind production," he added.

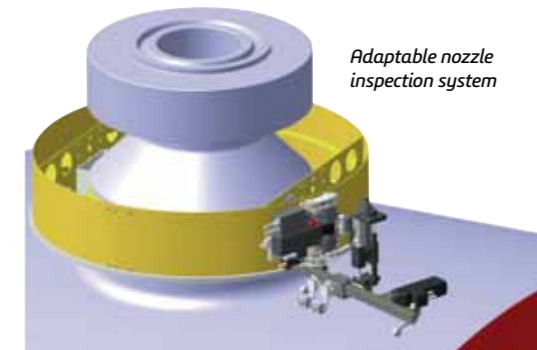

Adaptable nozzle inspection system

OPTIMAL PERFORMANCE OF A DEVICE

With the help of DELMIA, FORCE Technology equipment can be designed to obtain the best possible results during an inspection. In effect, simulation with DELMIA helps FORCE Technology optimize the nominal cycle time of a manipulator as well as its performance, eliminate collisions during the simulation phase, and implement design changes early and quickly. "In the past, we could not see problems before the machine was built," Lauritzen said. "But with DELMIA, we foresee the problems early and can correct the design, confident that when it will be built, it will not generate errors. Ramp-up time is faster thanks to DELMIA."

SALES SUCCESS RATE HAS GONE UP

3D DELMIA animations of the proposed solution help FORCE Technology's sales force communicate more effectively, replacing documents and words with a visual experience. "It helps build customer confidence," Lauritzen said.

Manipulators are expensive equipment and customers need to know that FORCE Technology can handle the job. And the 3DXML Player, currently used by the sales force to communicate with one another, will soon be extended to production to show how a manipulator should be assembled. "This will promote better collaboration between the design and production departments," Lauritzen commented.

FROM ONE-OF-A-KIND TO STANDARD REUSABLE COMPONENTS

CATIA PLM Express, with its integrated ENOVIA SmarTeam capabilities, is important to FORCE Technology since production has increased over the years and a more standard data structure is necessary.

"Before, we opted for one-of-a-kind components for each project, but over the years we have been using more and more standard components, which we can equip with different tooling depending on what needs to be inspected," Lauritzen said. "We are creating a database that contains all our standard components and their associated specifications so that everyone will know which components to use. Thanks to ENOVIA SmarTeam, the data will be readily available to them."

Collaborating on the same model is another short-term goal for FORCE Technology. "We already had cases where one developer was working on a model and another was working on the same model, which resulted in conflicting data problems," Lauritzen explained. "We definitely want to have more people collaborating on the same model simultaneously; this will be possible with ENOVIA SmarTeam".

With DELMIA, we foresee the problems early and can correct the design, confident that when it will be built, it will not generate errors. Ramp-up time is faster.

Brandt Lauritzen
Project Manager
FORCE Technology

For more information:
www.force.dk
www.delmia.com

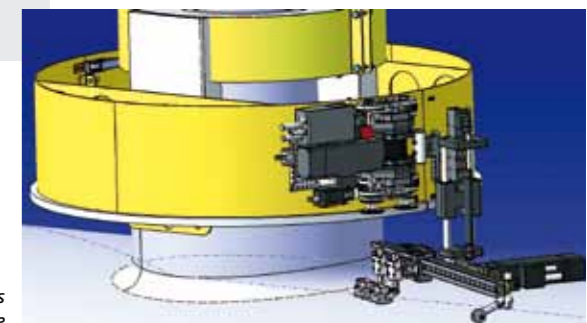

Robot inspects and welds sandwich cone structure